



DEMO TRUCKS

SCANIA WINTER 2025



SCANIA



	Type Designation	Bodybuild	Cab
1	560 R B6x6HA	Plow/blade / Istrail	CR20N
2	770 S B6x4NB	Tipper / OP Höglunds	CS20H
3	530 S B8x4*4NB	Hook lift / JOAB	CS20N
4	660 R A6x4HB	Trailer / Tipper trailer	CR20N
5	560 R B6x4HB	Dumper / Istrail	CR20N
6	560 R A6x2NB	Trailer	CR20H
7	660 S A6x4NB	Trailer	CS20H
8	45 R A4x2NB	Trailer	CR20H
9	590 R B6x4HZ	Dumper / Scania CV	CR20N
10	460 R A6x2NB	Trailer / LNG WVTA	CR20H
11	770 R A6x4NB	Trailer / WVTA	CR23H
12	460 R A6x4HB	Trailer / Tipper trailer CNG	CR20N
13	560 R B8x2*6NB	Flatbed with crane - HIAB	CR20N
14	25 P B4x2NB	Demo 402	CP17N
15	45 R B6x2*4NB	Demo 409	CR20N
17	40 R B6x2*4NB	Box / Thunderbolt	CR20N
18	45 R A4x2NB	Trailer / Pinus	CR20H
19	45 R A4x2NA	Trailer / Flash	CR20H



560 R B6X6HA

5753180



SCANIA WINTER

SCANIA



Specification

Chassis

Chassis number

YS2R6X60005753180

Axle distance

3,650 mm

Engine

DC13 173 / 560 hk / 2,800 Nm / Euro 6

Gearbox

G33CM – 14 gears split/range

Power take-off

Engine mounted, ED10R WBP1

Fuel tanks

395 L (medium) VS* + 80L AdBlue HS

Brakes

Drum brakes, R4700D retarder and engine brake (200 kW / 2,400 o/min).

Front axle

Leaf spring / AMD600TZP / 10,000 kg

Rear axle

Air suspension / AD400TAP / RBP835 / ratio 4.09 / 26,000 kg (13,000 + 13,000)

Tyre dimensions

385/65R22.5 - 315/80R22.5 - 315/80R22.5

Technical GTW

66,000 kg

Cab

CR20N / R sleeper cab with normal height. Black colour "Ebony Black"

Other equipment

- LED head lights
- Premium seat with black leather interior pack
- 6 kW cab heater/engine heater
- Electrical adjustable mirrors
- Airbag in steering wheel and side windows
- XT

Bodybuild

Istrail dumper

- Tipper volume: approximately 11.8 m³
- Bottom: 8 mm HB 450
- Sides: 6 mm HB 450
- Spreading limb: Hydraulic double-hinged
- Automatic limb: Hydraulic type
Height: 400 mm
- Exhaust heating of the entire bottom, with switch in cab
- Electro-pneumatic hydraulic central
- 130 L variable hydraulic pump mounted on existing engine power take-off with gearing, from factory. Emergency stop in accordance with CE regulations
- 200 L hydraulic tank
- Oil cooler Fira 46A
- Plow hydraulics, lift, lower, float and swing
- Hydraulic coupling for sand/salt spreader, with LS for fixed or variable oil volume
- Mählers center-mounted cutter, type HB3N
- Plow attachment, Scania / Mählers
- Front bar with plow and turn signal lights
- Operation: Switches in the cab and control panel on the armrests, type MC3
- Switch in steps for easier connection of the plough
- Trailer hitch: VBG 795V with air servo
- Aluminium mud guards with mud flaps
- The auxiliary frame and underside of the tipper box are galvanised
- Tipper box painted in "Ebony Black"



770 S B6X4NB

2204102



SCANIA WINTER

SCANIA



Specification

Chassis

Chassis number

YS2S6X40002204102

Axle distance

4,550 mm

Engine

DC16 123 / 770 hk / 3,700 Nm / Euro 6

Gearbox

G38CM - 14-speed split gearbox with creep gear and overdrive

Power take-off

Gearbox mounted, EG8R DCP1B (800Nm)

Fuel tanks

485 L (large) VS + 150L AdBlue HS

Brakes

Disc brakes, R4700D retarder and engine brake (300 kW / 2,400 o/min)

Front axle

Air suspension / AM660S / 9,000 kg

Rear axle

Air suspension / AD400SAP / RBP735 / ratio 3,52 / 21,000 kg (10,500 + 10,500)

Tyre dimensions

385/65R22.5 - 295/80R22.5 - 295/80R22.5

Technical GTW

80,000 kg

Cab

CS20H / S sleeper cab with high ceiling. Colour: Blue metallic "Sapphire blue"

Other equipment

- LED premium lights
- Premium seat with V8 black leather. V8 interior with red contrast
- 6 kW cab/engine heater
- Electrically adjustable mirrors
- Safety package (airbag in steering wheel and on side window)

Bodybuild

OP Höglunds timber bodybuild

Aluminium timber bodybuild

- Length: 7,300 mm
- Timber Gate: 3,100 mm

Equipment

Aluminium front wall

Parker 130 L variable pump

Hydraulic tank 225 L aluminium 3"

Water heating for the crane cab

Tank protection with brackets mounted on each side.

OP CC700 crane support

Laxo LX timber banks with 2.9 m stakes and integrated air tensioners

Rubber fenders for grapple and crane arm

Side barriers

VBG 795VR-3 hitch with air servo

2 support leg plates with holders

Slirej 650B sand spreader with quick release and air bellow

OP Ø20 cm storage box

Aluminium mud guards and OP chain holders

Timber crane

Loglift -125Z-93 with Hi-Cab

- Double extension, hydraulic reach 9.3 m
- Manoeuvring valve Olsberg Q300
- Electric control
- Support legs with hydraulic manoeuvring
- Hi-Cab cab with water heating
- Rotator GV12SAY
- Grapple HIAB X53



530 S B8X4*4NB

2203450



SCANIA WINTER

SCANIA



Specification

Chassis

Chassis number

YS2S8X40002203450

Axle distance

3,550 mm

Engine

DC16 120 / 530 hk / 2,800 Nm / Euro 6

Gearbox

G33CM - 14-speed split gearbox with creep gear and overdrive

Power take-off

Engine mounted, ED160P

Fuel tanks

485 L (large) VS + 105 L AdBlue HS

Brakes

Disc brakes, R4700D retarder and engine brake (300 kW / 2,400 o/min).

Front axle

Air suspension / AM660S / 9,000kg

Rear axle

Air suspension / AD400SA/ AM602SA / RB885 / ratio 3.07 / 28,000 kg (9,900 + 9,900 + 8,200)

Tyre dimensions

385/65R22.5 - 295/80R22.5 -
295/80R22.5 - 385/65R22.5

Technical GTW

66,000 kg

Cab

CS20N / S sleeper cab with normal height, colour red metallic, "Red Ruby"

Other equipment

- LED premium light package
- Premium seat with V8 black leather. V8 interior with red contrast
- 6 kW cab/engine heater
- Electrically adjustable mirrors
- Safety package (airbag in steering wheel and on side window)

Bodybuild

JOAB hook lift

- L24 ECO-Drive
- Capacity: 24 tonnes
- Telescopic arm with fixed tower
- Length: 5,750 mm
- Height: 198 mm
- Tipping angle: 50°
- Tipping torque amplifier has built-in rollers for friction-free horizontal movement of the bed
- Automatic lowering speed reduction
- Double action hydraulic valve with hose-break valve
- Mechanic pivot lock and external bed lock
- 108 L hydraulic pump mounted on existing engine power take-off with gear kit from Scania
- System pressure 285 bar
- 130 L hydraulic tank
- Manoeuvring: Electrical control, joystick and switch in cab
- Hitch: VBG 795 V air servo
- JOAB 600 mm manual underrun protection
- Scania original side skirts
- Painting: Scania chassie grey
- Technical kit
- Prepared for crane 22 tm
- Memory and auto cycle system



660 R A6X4HB

5754313



SCANIA WINTER

SCANIA



Specification

Chassis

Chassis number

YS2R6X40005754313

Axle distance

3,350 mm

Engine

DC16 122 / 660 hk / 3,300 Nm / Euro 6

Gearbox

G33CM - 14-speed split gearbox with creep gear and overdrive.

Power take-off

Engine mounted, ED160P

Fuel tanks

395 L (large) VS + 123 L AdBlue (HS)

Brakes

Disc brakes, R4700D retarder and engine brake (300 kW / 2,400 o/min).

Front axle

Air suspension / AM622S / 9,000 kg

Rear axle

Air suspension / AD400SA / RB885 / LDTA / ratio 3,42 / 26,000 kg (13,000 + 13,000)

Tyre dimensions

385/65R22.5 - 315/80R22.5 - 315/80R22.5

Technical GTW

66,000 kg

Cab

CR20N / R sleeper cab with normal height
Colour: silver metallic, "Arctic Silver"

Other equipment

- LED premium light package
- Premium seat with V8 black leather. V8 interior with red contrast
- 6 kW cab/engine heater
- Electrically adjustable mirrors
- Safety package (airbag in steering wheel and on side window)
- XT

Bodybuild

5th wheel

JOST cast disc without slider, height 185 mm (JSK37C-Z)

- D-value: 152 kN
- U-value: 20 tonn
- Height: 185 mm
- Material: cast iron
- Weight: 149 kg
- Kingpin size: 2"
- Fixed to the mounting plate

Gangway

Gangway, aluminium (five-bar) front and behind 5th wheel. The gangway can easily be lifted on the sides for easy access to diesel and AdBlue tanks

Toolbox

Toolboxes in combination with Scania original side skirts.

Hydraulics

Hydraulics for tipper semitrailer with tank behind cab. 225 L. 100 L Parker pump. Bodybuild by Norsk Scania.

Height 5th wheel

1,357 mm



560 R B6X4HB

5749457



SCANIA WINTER

SCANIA

OVERVIEW



Specification

Chassis

Chassis number

YS2R6X40005749457

Axle distance

3,350 mm

Engine

DC13 173 / 560 hk / 2,800 Nm / Euro 6

Gearbox

G33CM - 14-speed split gearbox with creep gear and overdrive.

Power take-off

Engine mounted, ED10R WBP1

Fuel tanks

440 L (large) VS + 105 L AdBlue HS

Brakes

Disc brakes, R4700D retarder and CRB engine brake (350 kW / 2,400 o/min).

Front axle

Air suspension / AM622S / 9,000 kg

Rear axle

Air suspension / AD400SA / RB885 – R885 / ratio 3.42 / 21,000 kg (10,500 + 10,500)

Tyre dimensions

385/65R22.5 - 315/80R22.5 - 315/80R22.5

Technical GTW

66,000 kg

Cab

CR20N / R sleeper cab with normal height. Colour: blue metallic, "Sapphire blue"

Other equipment

- LED premium light package
- Premium seat with black leather interior package
- 6 kW cab/engine heater
- Electrically adjustable mirrors
- Safety package (airbag in steering wheel and on side window)

Bodybuild

Istrail dumper

- Volume: approx. 10.9 m³
- Bottom: 7 mm TUF 500
- Sides: 5 mm TUF 500
- Dropside: Automatic ,steel, hinged
- Automatic dropside: Hydraulic, height: 300 mm
- Exhaust heating of the entire bottom with switch in cab
- Electro-pneumatic hydraulic central
- 80 L hydraulic pump mounted on existing engine power take-off with factory gear kit.
- Emergency stop according to CE regulations
- 100 L hydraulic tank
- Operation: switch in cab
- Trailer hitch: VBG 795V
- Aluminum mud guards with mud flaps
- The auxiliary frame and underside of the tipper box are galvanised

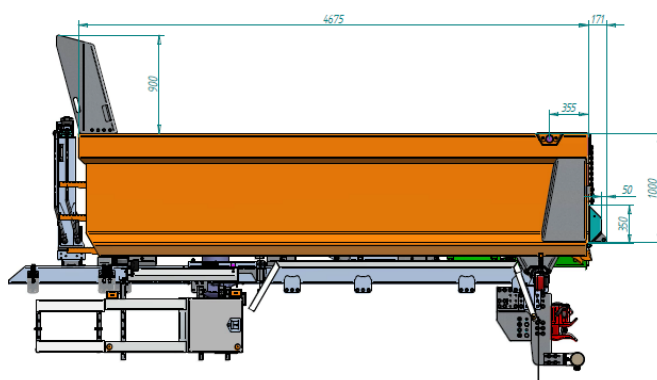



560 R A6X2NB

2203135



SCANIA WINTER

SCANIA



Specification

Chassis

Chassis number

YS2R6X20002203135

Axle distance

3,150 mm

Engine

DC13 173 / 560 hk / 2,800 Nm / Euro 6

Gearbox

G33CM - 14-speed split gearbox with creep gear and overdrive

Power take-off

Without Power take-off

Fuel tanks

565 L (large) VS + 150 L AdBlue HS

Brakes

Disc brakes, R4700D retarder and CRB engine brake (350 kW / 2400 o/min).

Front axle

Air suspension / AM640S / 9,000 kg

Rear axle

Air suspension / AD400SA/A600SA / R885 / ratio 2.69 / 19,000 kg (10,500 + 8,500)

Tyre dimensions

385/65R22.5 - 295/80R22.5 - 295/60R22.5

Technical GTW

66,000 kg

Cab

CR20H / R sleeper cab with high ceiling. Colour: grey metallic "Urban grey"

Other equipment

- LED premium light package
- Premium seat with black leather interior package
- 6 kW cab/engine heater
- Electrically adjustable mirrors
- Safety package (airbag in steering wheel and on side window)

Bodybuild

5th wheel

JOST JSK 37 EWPJ 173 cast disc with air-operated slider, height 173 mm with sensor for locked slider.

- D-value: 152 kN
- U-value: 20 tonnes
- Height: 173 mm
- Material: Cast iron
- Weight: 242 kg
- Kingpin Size: 2"
- Locking mechanism for slider: Pneumatic
- Adjustable distance in 13 steps of 50.8 mm. Total 660 mm.

Gangway

Aluminum gangway supplied by Scania

Height 5th wheel

1,210 mm



660 S A6X4NB

2203061



SCANIA WINTER

SCANIA

OVERVIEW



Specification

Chassis

Chassis number

YS2S6X40002203061

Axle distance

3,150 mm

Engine

DC16 122 / 660 hk / 3,300 Nm / Euro 6

Gearbox

G33CM - 14-speed split gearbox with creep gear and take-over

Power take-off

Without power take-off

Fuel tanks

565 L (large) VS + 105 L AdBlue HS

Brakes

Disc brakes, R4700D retarder and Engine brake (300 kW / 2,400 o/min)

Front axle

Air suspension / AM640S / 9000kg

Rear axle

Air suspension / AD400SA / RB885 / LDTA / ratio 3.07 / 21,000 kg (10,500 + 10,500)

Tyre dimensions

385/65R22.5 - 295/80R22.5 - 295/80R22.5

Technical GTW

66,000 kg

Cab

CS20H / S sleeper cab with high ceiling. Colour: silver metallic, "Arctic silver"

Other equipment

- LED premium light package
- Premium seat with V8 black leather, V8 interior with red contrast
- 6 kW cab/engine heater
- Electrically adjustable mirrors
- Safety package (airbag in steering wheel and on side window)

Bodybuild

5th wheel

JOST JSK 37 EWPJ 173 cast 5th wheel with air operated slider. Height: 173 mm with sensor for locked slider

- D-value: 152 kN
- U-value: 20 tonnes
- Height: 173 mm
- Material: Cast iron
- Weight: 242 kg
- Kingpin Size: 2"
- Locking mechanism for slider: Pneumatic
- Sliding 5th wheel. Sliding distance in 13 steps of 50.8 mm. Total 660 mm

Gangway

Aluminum gangway. The gangway can easily be lifted for easy access for filling diesel and Ad-Blue

Height 5th wheel

1,210 mm



45 R A4X2NB

2203227



SCANIA WINTER

SCANIA

Specification

Chassis

Chassis number

YS2R4X20002203227

Axle distance

4,150 mm

Electric machine

EM 450 C3-6
3,500 Nm

Power take-off

EL60DC1 / EG15R DCP1

Energy storage

Total capacity at 624 kWh

Brakes

Disc brakes, regeneration

Front axle

Air suspension / AM640S / 9,000 kg

Rear axle

Air suspension / AD400SA / R780 / ratio
4.25 / 13,000 kg

Tyre dimensions

385/65R22.5 - 315/70R22.5

Technical GTW

60,000 kg

Cab

CR20H / R sleeper cab with high ceiling.
Colour red metallic, "Red Ruby"

Other equipment

- LED premium light package
- Premium seat with black leather interior package
- Electrically adjustable mirrors
- Electric sun blind
- Airbag in the steering wheel and on the side window

Bodybuild

5th wheel

JOST JSK37C-Z 150

D-value: 152 kN

U-value: 20 tonnes

Height: 150 mm

Material: Cast iron

Weight: 150 kg

Kingpin size: 2"

5th wheel displacement: - 810 mm



Gangway



Height 5th wheel

1,174 mm



590 R B6X4HZ

2203997



SCANIA WINTER

SCANIA



Specification

Chassis

Chassis number

YS2R6X40002203997

Axle distance

3,350 mm

Engine

DC16 121 / 590 hk / 3,050 Nm / Euro 6

Gearbox

G33CM - 14-speed split gearbox with creep gear and overdrive.

Power take-off

Engine mounted, ED160P

Fuel tanks

395L (medium) VS + 80L AdBlue HS

Brakes

Disc brakes, R4700D retarder and engine brake (300 kW / 2,400 o/min).

Front axle

Leaf suspension / AM600S / 9,000 kg

Rear axle

Leaf suspension / AD400SZP / RBP735 / ratio 3.52 / 21,000 kg (10,500 + 10,500)

Tyre dimensions

385/65R22.5 - 295/80R22.5 - 295/80R22.5

Technical GTW

66,000 kg

Cab

CR20N / R normal height sleeper cab.
Colour: red metallic, "Red Ruby"

Other equipment

- LED premium light package
- Premium seat with black leather interior package
- 6 kW cab/engine heater
- Electrically adjustable mirrors
- Safety package (airbag in steering wheel and on side window)

Bodybuild

Istrail dumper / Scania CV

- Volume: approx. 11 m³
- Bottom: 8 mm HB 450
- Sides: 6 mm HB 450
- Drop side: Detachable, steel, front-hinged
- Automatic drop side: Hydraulic Height: 400 mm
- Exhaust heating of bottom
- Electro-pneumatic hydraulic center
- 80 L hydraulic pump mounted on existing engine power take-off with factory gear kit. Emergency stop according to CE regulations
- 100 L hydraulic tank
- Operation: switch in cab
- Trailer hitch: VBG 795 V
- Aluminum mud guards with mud flaps
- The auxiliary frame and underside of the tipper box are galvanised



460 R A6X2NB

5762138



SCANIA WINTER

SCANIA



Specification

Chassis

Chassis number

YS2R6X20005762138

Axle distance

3,850 mm

Engine

OC13 104 / 460 hk / 2,300 Nm / Euro 6

Gearbox

G25CM – 14 speed split gearbox with creep gear and overdrive

Power take-off

Without power take-off

Fuel tanks

LNG - 511 dm³ (VS) + 363 dm³ (HS).
Total: 343 kg

Brakes

Disc brakes and R4700D retarder with "free wheel function"

Front axle

Air suspension / AM640S / 9,000kg

Rear axle

Air suspension / AD400SA / A600SA / R885
/ ratio 2.87 / 21,000 kg (11,500 + 9,500)

Tyre dimensions

385/65R22.5 - 295/80R22.5 -
295/60R22.5

Technical GTW

66,000 kg

Cab

CR20H / R sleeper cab with high ceiling.
Colour blue, "Blue Royal"

Other equipment

- LED premium light package
- Premium seat with black leather interior package
- 6 kW cab/Engine heater
- Electrically adjustable mirrors
- Safety package (Airbag in steering wheel and on side window)

Bodybuild

5th wheel

JOST JSK 37 EWPJ 173 cast Disc with air operated slider. Height: 173 mm with sensor for locked slider

- D-value: 152 kN
- U-value: 20 tonnes
- Height: 173 mm
- Material: Cast iron
- Weight: 242 kg
- Kingpin Size: 2"
- Locking mechanism: Pneumatic
- Adjustable in 13 steps of 50.8 mm. Total 660 mm

Gangway

Gangway in aluminum (Bolt-On)



770 R A6X4NB

2205562



SCANIA WINTER

SCANIA



Specification

Chassis

Chassis number

YS2R6X40002205562

Axle distance

3,350 mm

Engine

DC16 123 / 770 hk / 3,700 Nm / Euro 6

Gearbox

GRS0926R, 12-stage reinforced range/split with creep gear and retarder

Power take-off

Without power take-off

Fuel tanks

650L (stor) VS + 150L AdBlue HS

Brakes

Disc brakes, R4100D retarder and engine brake (300 kW / 2,400 o/min)

Front axle

Air suspension / AM640S / 10,000 kg

Rear axle

Air suspension / AD400SAP / RBP735 / ratio 3.52 / 26,000 kg (13,000 + 13,000)

Tyre dimensions

385/65R22.5 - 295/80R22.5 - 295/80R22.5

Technical GTW

100,000 kg

Cab

CR23H / XL R sleeper cab with high ceiling. Colour: grey metallic, "Urban grey"

Other equipment

- LED premium light package
- Premium seat with V8 black leather. V8 interior with red contrast
- 6 kW cab/engine heater
- Electrically adjustable mirrors
- Safety package (airbag in steering wheel and on side window)

Bodybuild

5th wheel

JOST JSK 37 EWPJ 203 cast Disc with air operated slider. Height: 203 mm with sensor for locked 5th wheel

- D-value: 152 kN
- U-value: 20 tonnes
- Height: 203 mm
- Material: Cast iron
- Weight: 250 kg
- Kingpin Size: 2 "
- Locking mechanism: Pneumatic
- Sliding 5th wheel. Sliding distance in 13 steps of 50.8 mm. Total 660 mm

Gangway

Gangway, aluminium (five-bar) front and behind 5th wheel. The gangway can easily be lifted on the sides for easy access to diesel and AdBlue tanks.

Height 5th wheel

1,240 mm



460 R A6X4HB

5763181



SCANIA WINTER

SCANIA



Specification

Chassis

Chassis number

YS2R6X40005763181

Axle distance

3,750 mm

Engine

OC13 104 / 460 hk / 2,300 Nm / Euro 6

Gearbox

G25CH - 14-speed split gearbox with creep gear and overdrive - HD version

Power take-off

Engine mounted, ED120P

Fuel tanks

CNG - 8x95 dm³ (VS+HS) + 2x235 dm³.
Totalt: 234 kg

Brakes

Disc brakes og R4700D retarder with "free wheel function"

Front axle

Air suspension / AM622S / 9,000 kg

Rear axle

Air suspension / AD400SAP / RBP735 /
ratio 3.52 / 19,000 kg (9,500 + 9,500)

Tyre dimensions

385/65R22.5 - 315/80R22.5 - 315/80R22.5

Technical GTW

66,000 kg

Cab

CR20N / R normal height sleeper cab.
Colour: red, "Red Kreuger / Porsche Red"

Other equipment

- LED premium light package
- Premium seat with black leather interior package
- 6 kW cab/engine heater
- Electrically adjustable mirrors
- Electric sun visor
- Safety package (airbag in steering wheel and on side window)

Bodybuild

5th wheel

JOST JSK 37 EWPJ 203 cast disc with air operated slider. Height: 203 mm with sensor for locked slider

- D-value: 152 kN
- U-value: 20 tonnes
- Height: 203 mm
- Material: Cast iron
- Weight: 250 kg
- Kingpin Size: 2"
- Pneumatic locking mechanism for slider
- Sliding 5th wheel. Sliding distance in 13 steps of 50.8 mm. Total 660 mm

Gangway

Gangway in aluminum (Bolt-On)

Hydraulics

Hydraulic for tipper semi trailer with 225 L tank behind the cab. 100 L Parker pump. Built by Norsk Scania.

Height 5th wheel

1,335 mm



560 R B8X2*6NB

5722871



SCANIA WINTER

SCANIA



Specification

Chassis

Chassis number

YS2R8X20005722871

Axle distance

5,350 mm

Engine

DC13 173 / 560 hk / 2,800 Nm / Euro 6

Gearbox

G33CM - 14-speed split gearbox with creep gear and overdrive

Power take-off

EG9R DCP1B (860 Nm – 1.39/1.79)

Fuel tanks

395 L (large) HS + 47 L AdBlue (HS)

Brakes

Disc brakes, R4700D retarder and engine brake 300 kW / 2,400 o/min

Front axle

Air suspension / AM640S / 10,000 + 10,000 kg

Rear axle

Air suspension / AD400SA/AM602SA / R885 / ratio 2.87 / 21,000 kg (12,700 + 8,300)

Tyre dimensions

385/65R22.5 - 385/65R22.5 -
315/70R22.5 - 385/55R22.5

Technical GTW

66,000 kg

Cab

CR20N / R sleeper cab with normal height
Colour: grey metallic, "Urban grey"

Other equipment

- LED premium light package
- Premium seat with black leather interior package
- 6 kW cab/engine heater
- Electrically adjustable mirrors
- Safety package (airbag in steering wheel and on side window)
- Chassis frame is painted in Chilli red
- Original Scania rear fenders

Bodybuild

HIAB flatbed with crane

HIAB FrameWorks MSP auxillary frame

HIAB 190L Cyclone oil tank

HIAB 95 cc variable pump

Steel frame with bolted cross members.
L 6,546 mm W 2,548 mm. L 7,765 mm with extended rear. The extension is electrically powered. Front drop side H 1200.

9x12 tonnes lashing fasteners, one mounted in the rear part

Floor in waterproof veneer w/ thickness 27 mm

Extra pair of container locks for 20-foot container

Toolbox mounted behind rear wheels

3 toolboxes mounted on the left side

VBG 795V-3 hitch with air servo

Retractable underrun protection

Crane - HIAB IQ 958 E-8 HiPro JIB 155Q-6

IQ 958 8 hydraulic extensions to 19.7 m

JIB 155Q 6 extensions to 33.9 m and 760 kg

Hydraulic supported leg extension

Extra support leg beam

Support leg in front

6 slide valve V200 with CombiDrive 4 radio control and SPACE-EVO safety system

Switches for light, start, stop and speed

Other equipment

- Aluminium profile underrun protection that meets official requirements.
- Chain storage (2)
- Work lights (6.)
- Laxo stakes (10)
- All steel structures treated with nDurance, visible parts painted in RAL9005



40 R B6X2*4NB

THUNDERBOLT



SCANIA WINTER

SCANIA



Specification

Chassis

Chassis number

YS2R6X20002199609

Axle distance

4,750 mm

Electric machine

EM 400 C3-6
2,800 Nm

Power take-off

EG15R DCP1

Energy storage

Total capacity at 624 kWh

Brakes

Disc brakes, regeneration

Front axle

Air suspension / AM640S / 10,000 kg

Rear axle

Air suspension / AD400SA / AM602SA / R780
/ ratio 3.42 / 19,000 kg (11,500 + 7,500)

Tyre dimensions

385/65R22.5 - 315/70R22.5 - 385/55R22.5

Technical GTW

64,000 kg

Cab

CR20N / R sleeper cab with normal height
Colour: white, "Glacier White"

Other equipment

- LED premium light package
- Premium seat with black leather interior package
- Electric cab jack
- Electrically adjustable mirrors
- Electric sun blind
- Airbag in the steering wheel and on the side window

Bodybuild

Distribution box

SKAB



45 R A4X2NB

PINUS



SCANIA WINTER

SCANIA

Specification

Chassis

Chassis number

YS2R4X20002199559

Axle distance

4,150 mm

Electric machine

EM 450 C3-6
3,500 Nm

Power take-off

Without

Energy storage

Total capacity at 624 kWh

Brakes

Disc brakes, regenerereng

Front axle

Air suspension / AM640S / 9000kg

Rear axle

Air suspension / AD400SA / R756 /
ratio 3.36 / 11,500 kg

Tyre dimensions

385/55R22.5 - 315/70R22.5

Technical GTW

40,000 kg

Cab

CR20H / R sleeper cab with high ceiling.
Colour: green, "Mignonette Green"

Other equipment

- LED premium light package
- Premium seat with black leather interior package
- Electric cab jack
- Electrically adjustable mirrors
- Electric sun blind
- Airbag in the steering wheel and on the side window

Bodybuild

5th wheel

SAF HOLLAND SK-S 36.20 2 / 128

- D-value: 152 kN
- U-value: 20 tonnes
- Height: 128 mm
- Material: Cast iron
- Weight: 162.5 kg
- Kingpin size: 2"
- Displacement: -760 mm



Gangway



Height 5th wheel

1,152 mm



45 R A4X2NA

FLASH



SCANIA WINTER

SCANIA

Specification

Chassis

Chassis number

YS2R4X20002199583

Axle distance

4,150 mm

Electric machine

EM 450 C3-6
3,500 Nm

Power take-off

Without

Energy storage

Total capacity at 624 kWh

Brakes

Disc brakes, regeneration

Front axle

Leaf suspension / AM622S / 9,000 kg

Rear axle

Air suspension / AD400SA / R756 /
ratio 3.36 / 11,500 kg

Tyre dimensions

385/55R22.5 - 315/70R22.5

Technical GTW

44,000 kg

Cab

CR20H / R sleeper cab with high ceiling.
Colour: white, "Glacier White"

Other equipment

- LED premium light package
- Premium seat with black leather interior package
- Electric cab jack
- Electrically adjustable mirrors
- Electric sun blind
- Airbag in the steering wheel and on the side window

Bodybuild

5th wheel

SAF HOLLAND SK-S 36.20 2 / 128

- D-value: 152 kN
- U-value: 20 tonnes
- Height: 128 mm
- Material: Cast iron
- Weight: 162.5 kg
- Kingpin size: 2"
- 5th wheel location: -810 mm



Gangway



Height 5th wheel

1,152 mm



25 P B4X2NB

DEMO 402



SPECIFICATION - CHASSI NO: 2203466

P160U
ADAS Update
Smart Dash

DIMENSIONS

Axle distance	5550 mm
Length	9750 mm
Width	2600 mm
Height	3900 mm
Cab	CP17N

CAPACITY

Kerb weight	12125
Axle weight front	9000
Rear / Bogie	13000
GVW, Tech	22000
GTW, Tech	49000

POWERTRAIN

Engine	MG4115-1, Electric
Fuel	Electric
Max Torque	2200
Gearbox	GE21S22
Rear axle gear	R660
Rear axle gear ratio	4,88
Retarder	Without

DC GRAVEL ROADS

Track: Do not drive on gravel roads

SCANIA



45 R B6X2*4NB

DEMO 409



SPECIFICATION - CHASSI NO: 2203469

Smart and Safe

DIMENSIONS

Axle distance	4750 mm
Length	10240 mm
Width	2550 mm
Height	3850 mm
Cab	CR20N

POWERTRAIN

Engine	MG4130-3 001, 450kW
Fuel	Electric
Max Torque	3500
Gearbox	GE281
Rear axle gear	R780
Rear axle gear ratio	4,25
Retarder	Without

CAPACITY

Kerb weight	14165
Axle weight front	9000
Rear / Bogie	19000
GVW, Tech	28000
GTW, Tech	74000

DC GRAVEL ROADS

Track:

SCANIA